

Sentinel Eliminator Vortex[®] 500

Large filter for powerful magnetic filtration of system debris

Circulating debris in central heating systems can cause wear and premature failure of pumps, valves and heat exchangers. Sentinel Eliminator Vortex500, fitted to the return pipe on the boiler, will protect the system against all types of debris.

- **Large debris collection capacity and suitable for high flow rates, combined with in-line installation and 360° rotating T-piece**

Ideal where greater debris collection is required. Install quickly and simply onto pipework of any orientation

- **Flexible cleaning methods**

Providing fast and effective flushing on service or simple proof of collection

- **Manufactured to automotive standards with robust GRP body, dual seals and quality EU manufactured brass valves**

10 year guarantee for complete reassurance of long lasting quality

- **Unique Vortex Core with powerful neodymium magnet assembly**

Exertional retention of circulating system debris. Ensures the filter cannot block and can aid capture of other types of debris

22mm or 28mm isolation valves available

Dimensions
Height: 228mm
Width: 88mm

9,000 Gauss field

Max. flow rate
50 litres per minute



The Sentinel System

Lifetime protection for heating and hot water systems using the best practice process of...



CLEAN
WITH
APPROPRIATE
CLEANER



PROTECT
WITH X100
INHIBITOR



MAINTAIN
WITH
TEST KIT

Description

Sentinel Eliminator Vortex® system filter removes all types of debris commonly associated with wet central heating systems, affording boiler protection and helping to maintain optimum system operation and efficiency.

Operation

Sentinel Eliminator Vortex utilises a unique Vortex Core to deliver maximum contact time between circulation debris and powerful neodymium-iron-boron magnets. The Vortex Core reduces water flow rate and turbulence within the unit to enhance debris retention. It also ensures the filter will never block. The collected debris can be simply flushed away by removing the magnet from its sleeve and opening the drain valve at the base of the unit.

Additional features

Large collection capacity:	Suitable for use on systems that are larger, dirtier or have considerable circulating debris
Cannot block:	Full unit does not affect system operation
Tamper-proof:	Drain/flush valve safety feature
High flow:	Max. flow rate of 50 litres per minute
Dosing:	Compatible with Sentinel Rapid-Dose® (300ml)

Technical specifications

Maximum temperature:	100°C
Maximum operating pressure:	3 bar
Maximum flow rate:	50 litres/min
Mounting:	Main unit upright only - flow aligned with directional arrow
Connectors:	22mm and 28mm
Weight (boxed):	1.5kg (22mm); 1.6kg (28mm)

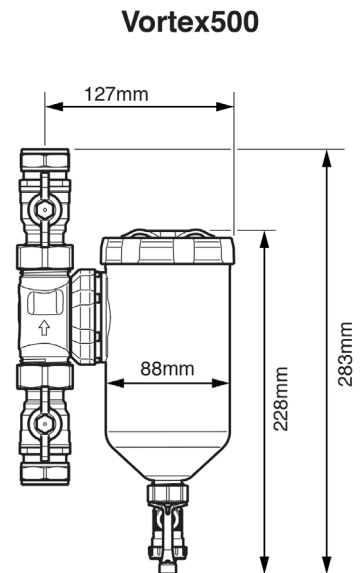

Pressure loss chart - Eliminator Vortex500

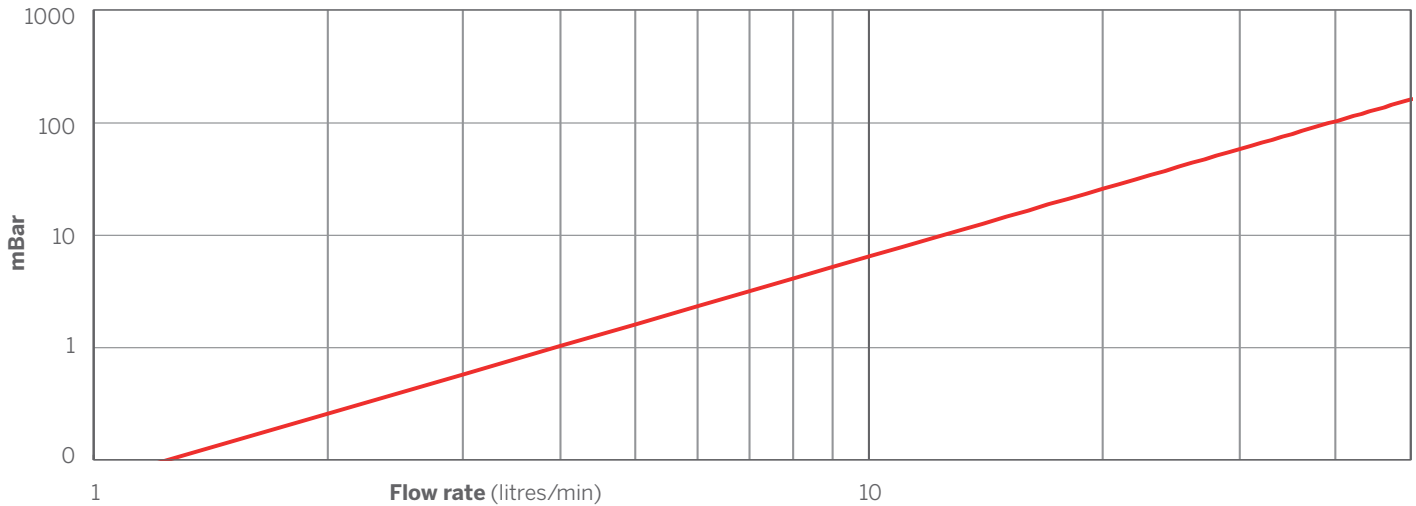

The use of Sentinel water treatment is endorsed by the industry's major international manufacturing companies*



Sentinel Performance Solutions Ltd

7650 Daresbury Park, Warrington, Cheshire, WA4 4BS, United Kingdom.

Tel: +44 (0)1928 704 330 www.sentinelprotects.com

